



# UNMUTED

13TH ASIA-PACIFIC CPO FORUM 2021 | 2&3 JUNE



"Enough of the polite conversation.

This year we've hit the 'unmute' - we're turning up the volume on the people and ideas that will be catalysts for change."

—Tania Seary, Founding Chair, The Faculty

# INTRODUCTION



Organisations depend on talent, but 'smarts' alone are not enough. The only way big thinkers, boundary pushers and innovators can truly flourish is in an inclusive, fearless workplace.

After 12+ months of near-continuous ambiguity and adjustment, it's time to take a breath and reset: What kind of workplace do you want to create? Where will your team find purpose? What will the C-Level expect of procurement in the new normal?

## **"YOU'RE ON MUTE" WAS THE CATCH CRY OF 2020...**

So in 2021, The 13th Asia-Pacific CPO Forum is feeling feisty and turning up the volume on the people and ideas that will be catalysts for change. Held virtually over two half-days on June 2 & 3, APAC's most senior procurement leaders will be challenged on the all the big issues:

- The unspoken story behind Australia's trade showdown with China
- Why it's time for procurement to speak up on sustainability
- Tailoring a social procurement message that's loud and clear for the CFO
- Giving voice to indigenous suppliers and building capability
- Toxic truths about the gender pay gap and why it's hurting your business more than the numbers show.



### **KEYNOTE SPEAKER**

#### **FORMER AUSTRALIAN PRIME MINISTER, THE HON. JOHN HOWARD OM AC**

...sharing his views on Australia's rift with China, the retreat of democracy, his appraisal of the current Government's pandemic performance, and why he still believes there is capacity for negotiation, progress and hope.



### **KEYNOTE SPEAKER**

#### **GRACE TAME, 2021 AUSTRALIAN OF THE YEAR**

...speaking out on her personal story of institutionalised trauma and how she fought to win the right to speak out under her own name. A challenging, disturbing, but deeply important mission.

## THE FEARLESS WORKPLACE

What does it take to pioneer an atmosphere of 'psychological safety' so employees of all levels, backgrounds and experience can raise difficult issues, highlight risks, 'unmute' controversial ideas and embrace mistakes as opportunities to learn?



**Futurist, London Business School and MIT Entrepreneur Mentor in Residence, Terence Mauri and master storyteller, Gabrielle Dolan,** inspire you to create an atmosphere that turns disruption into learning, innovation and advantage.



### TERENCE MAURI

**Founder, Hack Future Lab, Entrepreneur Mentor in Residence London Business School & MIT**

World's #1 global disruption thinker & best selling author



### GABRIELLE DOLAN

**Authentic Leadership Coach & Founder, Jargon Free Fridays**

Master storyteller and The Faculty Roundtable's #1 rated speaker

# GEOPOLITICS, MACRO ECONOMICS AND SOCIAL UNREST



After three decades of relatively congenial global economic relations, the Australian government is locked in a trade war with China, deeply indebted and reckoning with our treatment of women, minorities and the environment.



We go behind the year's biggest headlines with **Online Commentator, Voice for Victoria, Emily Coltraine** and **China Trade and Investment Expert, Helen Sawczak**, to understand where we have come from, where we are now, and where to from here.



**EMILY COLTRAINED**

**Voice for Victoria**

Breakout public interest commentator and online educator



**HELEN SAWCZAK**

**Former National CEO, The Australia China Business Council**

China trade and investment expert



## POWERING DIVERSITY AND INCLUSION

As the business case for gender, ethnic and cultural diversity continues to strengthen and businesses re-evaluate their employee and supply chain diversity strategies, what does it take to become a 'diversity winner'?



One of The Australian Financial Review's 100 Women of Influence, **Div Pillay** examines the toxic truths behind the gender pay gap and why a failure to harness the commercial and human benefits of inclusion is hurting your business more than the numbers show.



### **DIV PILLAY**

**CEO, MindTribe & Co-Founder, Culturally Diverse Women**

Race, culture, intersectional inclusion and equity advisor and Australian Financial Review's 100 Women of Influence

## EXPONENTIAL IMPACT ON ESG

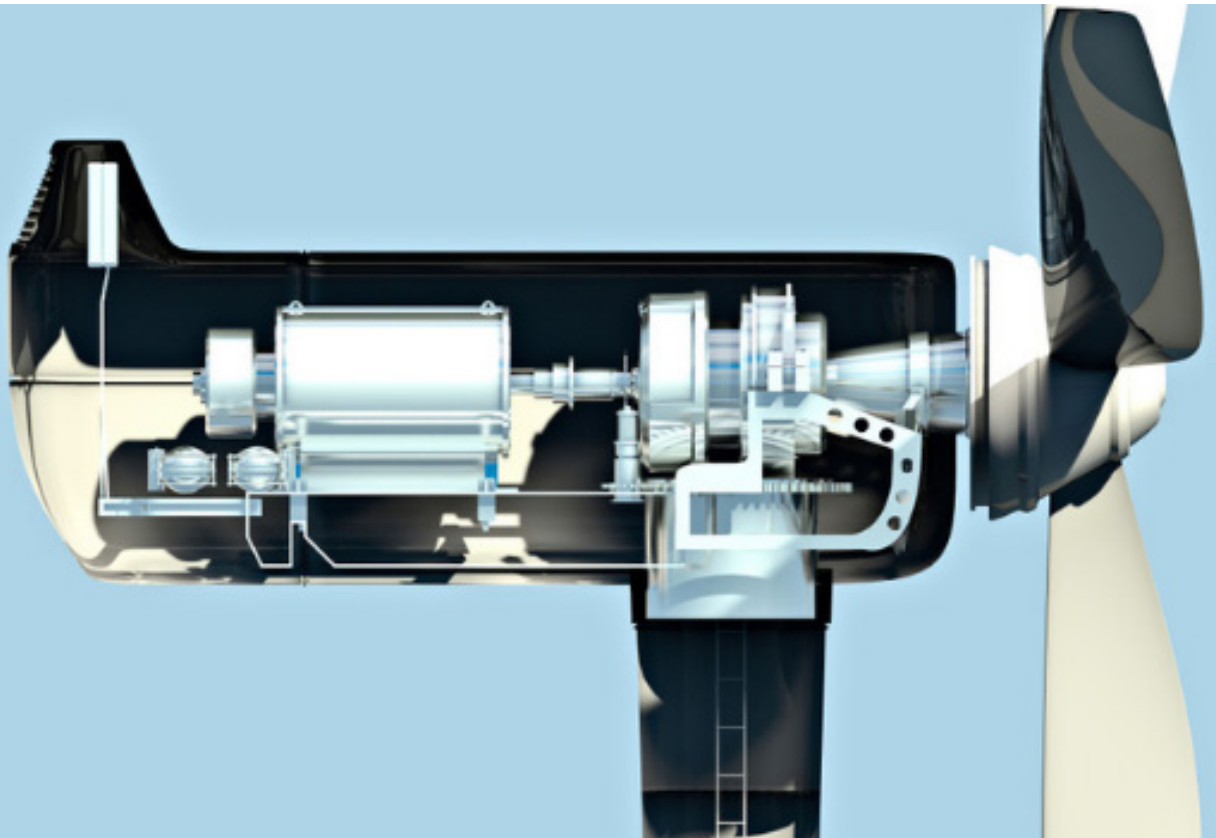

Supply chains are our single greatest channel for driving real world change – and they are also our largest single point of exposure and risk.

It's long past due that we shift from 'If and When' to 'Now and How'.

**Cain Liddle, CEO, Carlton Football Club, Jeff Niemski, GM Environmental Services, Crown Resorts and Yasmin Assis, Group Sustainability Lead, IKON Services Aust**, offer an APAC perspective on the strategies that have worked – and those that haven't – for selecting, motivating, engaging and collaborating with suppliers to achieve ESG goals.

# WHAT TO EXPECT

## INTERACTION

We're turning up the volume on the news headlines, issues and people that matter most. Global thought leaders spark long overdue conversations around procurement's potential to have an exponential impact on sustainability, the gender pay gap, indigenous businesses, and the Top 10 risks you need to know now.

## INNOVATION

Delegates will strategise actionable solutions to take back to their businesses. The Forum provides global perspectives and executive insights to address the issues that matter most for your organisation.

## ACCESS

Back by popular demand, **American Express** presents **The CFO Mentoring Zone**. Forum delegates will be matched with an A-Team of CFOs and Directors, led by **Former Rio Tinto CFO and Westpac Director, Chris Lynch** to talk through the C-suite's expectations of procurement in the new normal and help you to finesse conversations with your own CFO.

# WHO SHOULD ATTEND

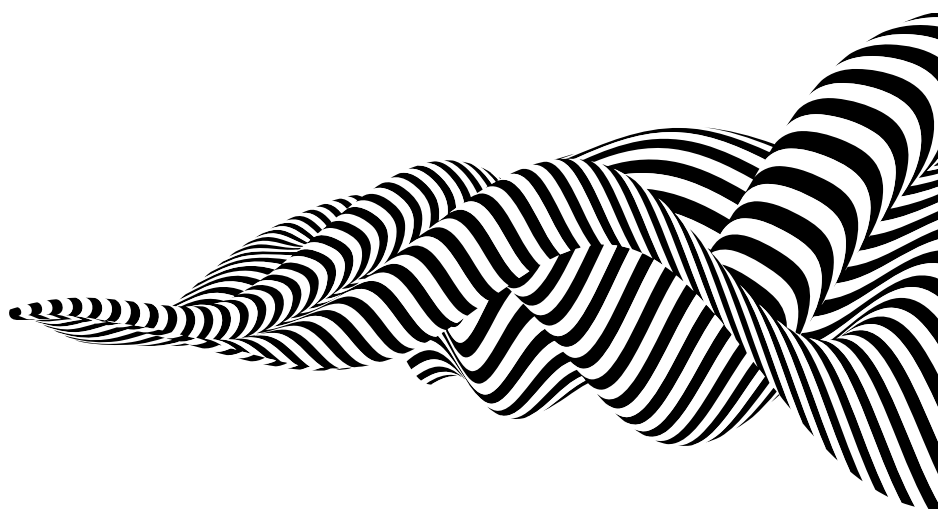

The preserve of Chief Procurement Officers for over a decade, **we're shaking up the invitation list in 2021** to ensure more voices are heard!

**We're encouraging CPOs to invite their lead team to speed the change agenda in their business.**

The Asia-Pacific CPO Forum 2021 is suited to:

- CPOs & Heads of Procurement
- CFOs
- Procurement Lead Team Executives

**"Thank you for continuing to ignite us!"**

- Naomi Lloyd, Global CPO and CPO Forum Alumni

**"Two of the most thought-provoking, inspirational days in the procurement calendar"**

- Tim Littlehales, Group Procurement Manager, Boral

# MEET OUR SPEAKERS



**THE HON. JOHN HOWARD OM AC**  
25th Prime Minister of Australia (1996–2007) and Leader of the Liberal Party (1985–1989; 1995–2007)



**TANIA SEARY**  
Founding Chair, The Faculty, Procurious & The Source  
Founder of the world's first online community for procurement & supply chain professionals



**GRACE TAME**  
2021 Australian of the Year  
Advocate for survivors of sexual assault and #LetHerSpeak campaigner



**GUSTAV ERLANDSSON**  
Associate Partner, McKinsey & Co  
10 years of industry experience from CPG and Pharma and extensive experience in Procurement



**JOANNE WRIGHT**  
Vice President Enterprise Operations & Services, IBM  
Former IBM Supply Chain VP, advocate for AI-enabled supply chain transformation and Fortune Magazine's Most Powerful Women Next Gen (2016, 2017)



**SHARAT CHIKATMARLA**  
Senior Expert, McKinsey & Co  
Procurement advisor helping APAC procurement leaders shape recovery in the 'next normal'



**CHRIS LYNCH**  
Former Rio Tinto CFO and Westpac Director  
CFO Mentoring Zone



**NICK DUNFORD**  
Country Manager ANZ, Uber for Business  
Thought leader on impact of technology, the future of cities, transport and work



**THOMAS UDESEN**  
EVP & Chief Procurement Officer, Bayer AG  
Accelerating positive impact as Co-Founder of The Sustainable Procurement Pledge



**PETE HAMILTON**  
VP and Regional Director, KellyOCG  
Leading global advisor on talent supply chain strategies and future of work



**LANCE YOUNGER**  
Founder, ProcureTech  
Procurement transformation and digital ecosystems evangelist



**ZOE CHERNIH**  
Senior Partnerships Manager, Westpac  
A chartered member of CIPS, procurement specialist in public and private sectors



# WHO YOU WILL MEET

# OUR PARTNERS



## 2019 ATTENDEES

American Express	FRDM
American Express Global Business Travel	Group Rail
AMP	IAG
ANZ	Lion
Ausgrid	McKinsey&Co
Australian Submarine Corporation	MMG
Australian Tax Office	Monash University
Australian Unity	Newcrest
Beeline	OZ Minerals
BP	PwC
Broadspectrum	Santos
Campbell Arnotts	Singapore Airlines
Canon	Star Entertainment Group
Cbus	Swinburne University of Technology
Coca Cola Amatil	TAFE NSW
Coupa	Telstra
Cricket Australia	Telstra Super
Crown Resorts	Toll
DBS Bank	Transgrid
Department of Economic Development, Jobs, Transport and Resources	Transurban
Department of Education	University of Melbourne
Department of Premier and Cabinet	Village Roadshow
Engie	Virgin Australia
Ernst&Young	V/Line
	Woodside
	Woolworths Group



**Kelly Outsourcing &  
Consulting Group**

**McKinsey  
& Company**

**Uber for Business**

**FCM**

**"The most informative  
Procurement event of the year"**

- Kevin McCafferty, Group Procurement  
Manager, Ventia Pty Ltd

# INVESTMENT

## Individual Ticket:

\$1500 + GST

## Leadership Team Group Package:

\$4500 + GST (RRP \$6000)

(Four tickets for the price of three)

## Roundtable Member Ticket:

\$1125 + GST

(25% discount)

## Roundtable Leadership Team Group Package:

\$3375 + GST (RRP \$6000)

(Four tickets for the price of three + further 25% discount)

Buy your individual ticket [here](#)

For Roundtable Tickets or Group Packages contact Adam Gillies via [adam.gillies@thefaculty.com.au](mailto:adam.gillies@thefaculty.com.au)

# DATE, TIME, LOCATION

## 2 June 2021

2pm-6pm AEST

followed by online Networking Drinks from 6-7:30pm

## 3 June 2021

9am-midday AEST

The Asia-Pacific CPO Forum 2021 will be hosted online via Procurious [here](#)

# CONTACT

Jacinta McKinnon

Major Events Manager

[jacinta.mckinnon@thefaculty.com.au](mailto:jacinta.mckinnon@thefaculty.com.au)

#CPOForum2021



# WHAT YOU'LL NEED

The 13th Asia-Pacific CPO Forum is a virtual event and we want to ensure you have the best possible experience.

You will need:

Computer and stable internet connection, Google Chrome browser recommended.



Quiet room or office recommended



Firewall permits access to Procurious



Compatibility with Zoom conferencing

